

SERVICE INFORMATION

Customer Service
Technical Office

2-Cyl. Motorcycles
R 50 US, R 60 US, R 69 US

New York, May 1969
No. USA-1

Group: Suspension - Shock Absorbers

Re: Telescopic Front Fork

Gentlemen:

Extensive testing with the telescopic front fork has revealed that better suspension is obtained, if the spacer, Part #31422000399, is removed.

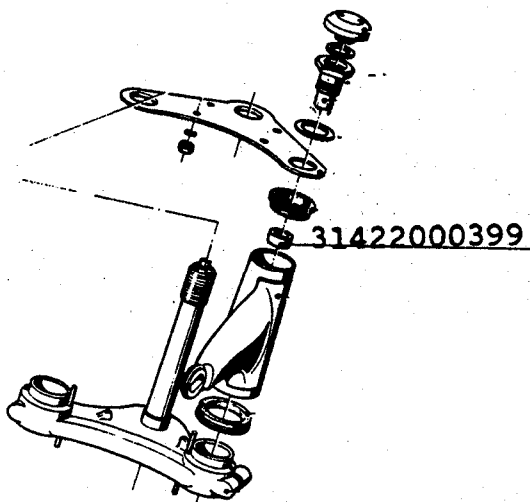

To remove the spacer, first remove the top cover and then the top spring retainer. After the spacer has been removed, reinstall the top spring retainer and torque to 87 ft.lbs.

We would like to remind you to use only the recommended hydraulic fluid for the telescopic fork. Either use Shell 4001, or Shell Aero-Hydraulic.

Initially, the fork has to be filled with 280cc per fork leg. If the fork is drained and refilled, then only 250cc per fork leg are required.

Very truly yours,

Bayerische Motoren Werke A.G.

Butler & Smith, Inc.

Volker Beer
Volker Beer
BMW Representative

Helmut M. Kern
Helmut M. Kern
Service Manager

Kenntnis genommen — Pris connaissance — Noted — Tomado nota — Preso conoscenza					Ablage — Archives — File — Archive		
Betriebsleitung	Werkstatt	KD-Annahme	Gewährl.-Sachb.	E-Teildienst	Betriebsleitung	Werkstatt	